

WIRING DIAGRAM

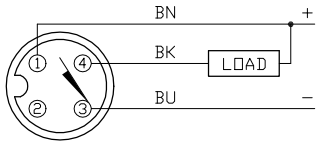

OUTPUT: AN4X2

SHORT-CIRCUIT AND OVERLOAD PROTECTED

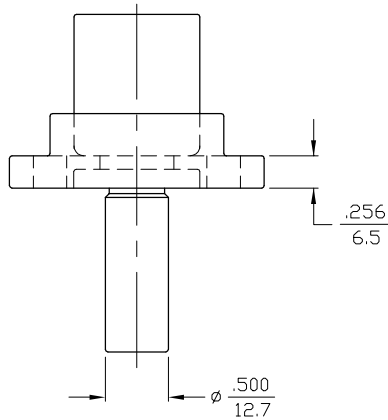
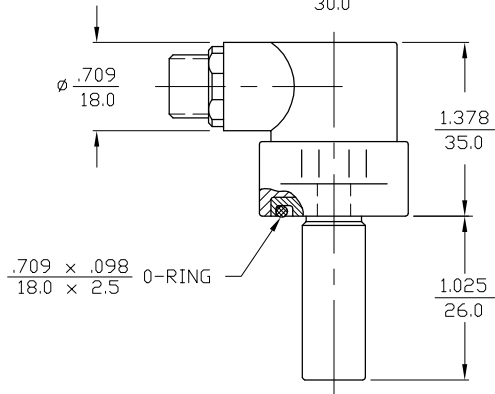
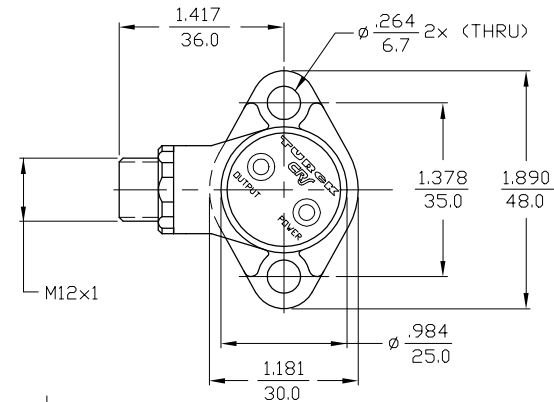

NOTE: PRELIMINARY SPECIFICATIONS

2. ROTATION CAPABILITY OF CRS SENSOR IS 360°.

NOTES: 1. "/S34" DESIGNATES WELD FIELD IMMUNITY. SENSOR IS SUITABLE FOR USE ON RESISTANCE MACHINES.

SPECIFICATIONS

OPERATING VOLTAGE	10-65 VDC
RIPPLE	≤10%
DIFFERENTIAL TRAVEL (HYSTERESIS)	3-15% (5% TYPICAL)
VOLTAGE DROP ACROSS CONDUCTING SENSOR	<1.8 V at 200 mA (1.3 V TYPICAL)
OUTPUT FUNCTION	NORMALLY OPEN 3-WIRE DC SELF-CONTAINED
TTL COMPATIBLE	NO
SHORT-CIRCUIT PROTECTED	YES
TRIGGER CURRENT FOR OVERLOAD PROTECTION	>220 mA
CONTINUOUS LOAD CURRENT	≤200 mA
OFF-STATE (LEAKAGE) CURRENT	<10 μA
NO-LOAD CURRENT	7.5 mA TYPICAL at 24 V DC 10.0 mA TYPICAL at 65 V DC
POWER-ON EFFECT PROTECTION	INCORPORATED
REVERSE POLARITY PROTECTION	INCORPORATED
WIRE-BREAK PROTECTION	INCORPORATED
PROTECTION AGAINST TRANSIENTS	<2 kV <1 ms <1 J
OPERATING TEMPERATURE	-25°C to +70°C (-13°F to +158°F)
ENCLOSURE	MEETS NEMA 1, 3, 4, 6, 13 AND IEC IP67
SHOCK	<30 g, <11 ms
VIBRATION	10 Hz to 55 Hz, ≤1 mm AMPLITUDE (IN ALL 3 PLANES)
LED FUNCTION	YELLOW: OUTPUT ENERGIZED GREEN: POWER ON
SENSING RANGE	2 mm = .079" (NOMINAL)
SWITCHING FREQUENCY	30 Hz MAX.
REPEATABILITY	<1% OF RATED OPERATING DISTANCE
OPERATING PRESSURE	1500 PSI
RESPONSE TIME	15 ms MAX.
EMBEDDABLE (SHIELDED)	YES
COLOR CODE	BLUE
MATING PLUGS/CABLES	4-PIN "EUROFAST" CONSTRUCTION

MATERIAL		3RD ANGLE PROJECTION				TURCK INC 3000 CAMPUS DRIVE MINNEAPOLIS, MN 55441 PHONE: (612) 553-7300	
FINISH		BLACK ZINC					
DRFT	RJP	DATE	6/11/96	PART NO./DESCR.			
DSGN		Y#		BI 2-CRS260-AN4X2-H1141/S34			
DIMENSION UNITS:				SIZE	ID NO.	REV	
INCHES				B	T4580004	P3	
[MILLIMETERS]				SCALE	NONE	T4580004	SHEET OF

REV	DESCRIPTION	DRFT	DATE	ECO NO.
REVISIONS				